

# ALPOLIC®/fr LT

## Outline of product

### 1. Suggested applications

Internal claddings such as wall, column, ceiling and partition of shop, office and factory. Light outdoor uses such as soffit, awning, parapet, signs and lining of tunnels.

### 2. Material composition

ALPOLIC®/fr LT is composed of non-combustible mineral filled core sandwiched between two skins of 0.3mm thick aluminum. The core consists of non-combustible mineral and small content of low-density polyethylene. The color of the core is gray for aesthetic purpose of the cut edge.

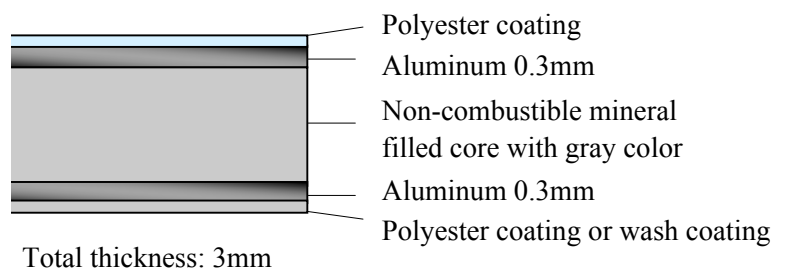

The effective sides are finished with several types of **polyester** coatings.

“Reversible Series” has effective sides on both top and back.

“Single, Stone Series and Timber Series” have an effective side on top and a wash coating on back.

The effective sides are covered with translucent protective films.

### 3. Surface finishes

The surface finishes include four types of polyester coatings: Reversible, Single, Stone and Timber.

**Reversible**, consisting of solid colors and metallic colors, has effective sides on both top and back.

**Stone** and **Timber**, having a stone- or timber-patterned surface, are coated with a unique image transfer process.

**Mat** finish is produced with a new coating technology in which uniform microscopic wrinkles are formed all over the surface, and accordingly, it appears a mat finish.

On stock colors, refer to the Color Chart. In addition to the stock colors, **custom colors** are available subject to respective minimum quantity and color match. Please contact distributors or our office for custom color request.

**Mat finish:** Due to the hardening speed difference between the outer and inner layers, microscopic wrinkles emerge over the entire surface. As a result of irregular light reflection, it looks a perfect mat.

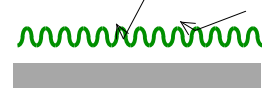

#### Coating method:

All the finishes are coated in the manufacturer’s continuous coil coating lines with polyester paints.

#### Optional coatings:

Apart from the above polyester coatings, we can supply ALPOLIC/fr LT products coated with the following distinctive paints as option. Refer to technical brochure for details.

Optional coating	Characteristics	Suitable application
Fluorocarbon coating (Lumiflon-based)	Ultra-weatherability Coating warranty is available	Outdoor (awning, parapet, sign)
High cross-link polyester coating	High hardness (4H) High reflectivity (80%)	Interior cover of tunnel
Conductive fluorocarbon coating	Electric-conductive ( $3 \cdot 10^{7-8}$ ohms)	Interior wall and partitions in factory

#### 4. Dimension and its tolerance

Panel thickness: 3 mm

Panel weight: 5.5 kg/m<sup>2</sup>

Panel size in stock:

Width: 1270 and 1575 mm

In Mat items, only 1270mm panels are in stock.

Length: 3099mm

Note: Custom width is available between 914 mm and the above width for each finish. Custom length less than 7200 mm can be accepted. Please contact distributors or our sales office for the minimum quantity and the lead-time of custom size.

Product tolerance:

Width: ±2.0mm

Length: ±4.0mm

Thickness: ±0.2mm

Bow: Maximum 0.5% of the length and/or width

Squareness: Maximum 5.0mm

Surface defect: The surface shall not have irregularities such as roughness, buckling and other imperfections in accordance with our visual inspection rules.

Edge condition: ALPOLIC/fr LT is supplied with a cut edge without aluminum sheet displacement and core protrusion.

#### 5. Characteristics

##### (1) Physical properties

The physical properties of ALPOLIC/fr LT can be summarized as follows:

	ASTM	Unit	ALPOLIC/fr LT
Specific gravity	-	-	1.84
Weight	-	kg/m <sup>2</sup>	5.5
		psf	1.13
Thermal expansion/ contraction ratio (linear)	D696	1/°C	$24 \cdot 10^{-6}$
		1/°F	$13 \cdot 10^{-6}$
Thermal conductivity	D976	W/(m·K)	0.31
		BTU/(ft·hr·°F)	0.17
Deflection temperature	D648	°C	110
		°F	230

## (2) Mechanical properties as ACM

ALPOLIC/fr LT has the following mechanical properties as a composite panel.

	ASTM	Unit	ALPOLIC/fr LT
Tensile strength	E8	MPa or N/mm <sup>2</sup> psi	30 4352
0.2% proof stress	E8	MPa or N/mm <sup>2</sup> psi	27 3916
Elongation	E8	%	4
Flexural elasticity, E	C393	MPa or N/mm <sup>2</sup> psi	33_10 <sup>3</sup> 4787_10 <sup>3</sup>
Flexural rigidity, E_I	C393	Nmm <sup>2</sup> /mm lbs.inch <sup>2</sup> /inch	74_10 <sup>3</sup> 655
Shear strength with punching shear test	D732	N/mm <sup>2</sup> psi	21 3046

## (3) Mechanical properties of aluminum skin (1100-H14)

The mechanical properties of aluminum skin, shown below, can be used for calculation of structural strength of ALPOLIC/fr LT panel. Refer to technical brochure for details of structural strength.

	ASTM	Unit	Aluminum 1100-H14
0.2% proof stress	E8	MPa or N/mm <sup>2</sup> psi	118 17_10 <sup>3</sup>
Flexural elasticity	E8	GPa or kN/mm <sup>2</sup> psi	69 10_10 <sup>6</sup>

## (4) Rigidity and panel weight

On the basis of the above mechanical properties, we can evaluate the rigidity of ALPOLIC/fr LT. The following table shows the thickness of various materials with the rigidity equivalent to ALPOLIC/fr LT. As shown in the table, ALPOLIC/fr LT has high rigidity with lightweight. It consists of 0.3mm plus 0.3mm thick aluminum skins, but the rigidity is equivalent to 2.4mm thick aluminum and 1.6mm thick steel sheets.

Material	Thickness of equivalent rigidity, mm (inch)	Weight kg/m <sup>2</sup> (psf)	Weight ratio (ALPOLIC=100)
ALPOLIC®/fr LT	3.0 (0.118")	5.5 (1.13)	100
Aluminum sheet	2.4 (0.094")	6.5 (1.33)	118
Steel sheet	1.6 (0.063")	12.6 (2.59)	230
Stainless steel (304)	1.7 (0.067")	13.4 (2.75)	244
Acrylic sheet	6.6 (0.260")	7.9 (1.62)	144

## (5) Impact resistance

The following data were obtained with Du-pont impact test.

Steel ball weight kg (lbs)	Height mm (inch)	Dent depth mm (inch)
0.3 (0.7)	300 (11.8")	1.0 (0.04")
0.5 (1.1)	500 (19.7")	2.0 (0.08")
1.0 (2.2)	300 (11.8")	2.3 (0.09")
1.0 (2.2)	500 (19.7")	3.1 (0.12")

Du-pont test instrument

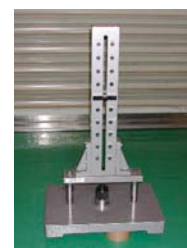

## (6) Fire performance

ALPOLIC/fr LT is a fire-safe interior material. It passes mandatory requirements for interior materials in USA and Japan. The core material contains small content of combustible polyethylene, but the main ingredient of the mineral does not permit the proliferation of the flame and restrict the development of the smoke detrimental to the evacuation activities.

ALPOLIC/fr LT passes the following fire tests:

Country	Test standard	Results & classification
United Kingdom	BS476 Part 6	Class 0
	BS476 Part 7	Class 1
USA	Tunnel Test (ASTM E-84)	Class A/Class 1
	Interior Room Corner Test (UBC 26-3)	Passed
Japan	Heat Release Test for Non-combustible Material (ISO5660-1) and Toxicity Gas Test	Passed. Certificate No. NM-0209

## (7) Bendable limit

ALPOLIC/fr LT is bendable by means of a press brake or a 3-roll bender. The minimum bendable radius with press brake is as follows.

Bending method	Condition		Minimum bendable radius (mm)
Press brake	Bending direction	Traverse	50
		Parallel	80

The bendable limit with 3-roll bender depends on the diameter of the bending roll as follows.

Bending method	Condition		Minimum bendable radius (mm)
3-roll bender	Roll length	500 mm	120
		1000 mm	150
		2000 mm	180
		2500 mm	200

## 6. Coating quality

### (1) Consistent color quality

In ALPOLIC/fr LT, paints are continuously applied on aluminum coil in coil coating line that permits consistent coating quality. The “Die Coating” on this line, which is very unique coating technology developed by Mitsubishi Chemical, ensures smooth and fine coating.

### (2) Paint performance

The polyester coatings of ALPOLIC/fr LT meet the following performance:

Test item	Test method	Performance
Paint thickness		
Gloss:	60° specular gloss (ASTM D523-89)	5% to 80%
Pencil hardness:	(ASTM D522-88)	>H
Adhesion (Cross-cut)	Adhesion (Cross-cut)	100/100 (Cross-cut)
Impact resistance:	Du-pont method, 0.5kg, 1/2 inch, 50cm, Backside impact test	No picking off

Test item	Test method	Performance
Water resistance:	50°C, tap water, 24 hrs.	100/100 (Cross-cut)
Boiling water resistance	98-100°C, pure water, 4 hrs.	100/100 (Cross-cut)
Humidity resistance:	240 hrs, 98% RH, 50°C (ASTM D2247-87)	No blister, no pick off
Alkali resistance:	1%NaOH, 20°C, 24hrs.	No blister, no pick off
Acid resistance:	5%H <sub>2</sub> SO <sub>4</sub> , 20°C, 24hrs.	No blister, no pick off
Salt spray resistance:	1000 hrs, salt fog, 35°C	No blister, no pick off
Solvent resistance:	MEK, 20°C, 24hrs.	No blister, no pick off
Detergent resistance:	Detergent “Surf”, 25g/30L, 20°C, 24hrs.	No blister, no pick off
Pollution resistance:	Lip stick, eye shadow, 24 hrs. After wiping off with IPA.	No blister, no pick off
Accelerated weathering test:	QUV, 500 hrs.	No blister, no pick off

### (3) Comments on paint performance

The above polyester coatings have sufficient corrosion resistance in interior applications. It withstands even moisture in bathroom. A reasonable weatherability can be expected also outdoor applications including soffit, parapet, awing and sign. But, as widely known, the fluorocarbon coating is the best as far as the weatherability is concerned.

If you require the more durable coating in outdoor applications, or if you require a coating warranty for your project, we recommend the fluorocarbon-coated product as an optional coating. We cannot submit a coating warranty with the polyester-coated products. Please contact distributors or our office.

### 7. Perforated panel

Perforated panel has numerous holes with constant interval on ALPOLIC/fr LT panel. As it permits to see the opposite side through it, it is suitable for cover panel of balcony, staircase and partition. Perforated panel also permits air ventilation. We can supply ALPOLIC/fr LT after perforation. Refer to technical brochure.

### 8. Summary of fabrication method

ALPOLIC/fr LT is easy to cut, bend, groove and shape with regular aluminum working and woodworking machines and tools. Typical fabrication methods are outlined below. Refer to technical brochure for details.

#### (1) Saw cutting

Various types of circular saws including table saw, hand circular saw and panel saw can cut ALPOLIC/fr LT. Carbide-tipped saw blades for aluminum and plastic, of which the rake angle is smaller than those for timber, are suitable.

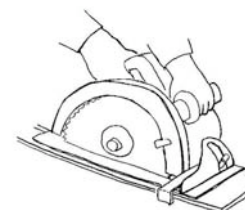

#### (2) U-grooving for folding

ALPOLIC/fr LT is foldable after U-grooving in the backside. Two types of machines are available for U-grooving. One is the circular cutter type and the other is the router type. The former type includes hand grooving machine and panel saw equipped with suitable grooving cutter. The latter type includes hand router and CNC router.

After U-grooving, ALPOLIC can be folded with folding jig, as shown below.

Hand grooving machine

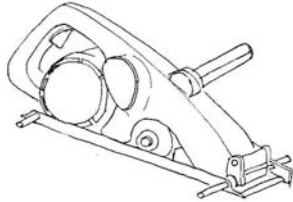

Grooving cutter



Handy router

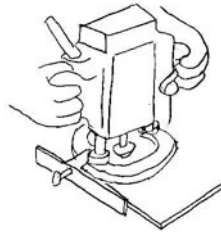

Router bit



<p>1. U-groove Leave 0.2-0.4 mm core.</p>	<p>2. Folding jig Folding jig is made of aluminum or steel angle.</p>	<p>3. Fold Use a little longer jig than folding length.</p>	<p>4. Roundness Suitable roundness is 2-3 mm R.</p>	<p>5. Support Support with aluminum angle, if necessary.</p>

**(3) Chamfering with hand trimmer or plane**

Edge can be chamfered with trimmer, equipped with a ball bearing chamfering bit. Regular woodworking bit is usable, but carbide-tipped bit with small rake angle gives better result. The suitable rotation of bit is 10,000 rpm or lower. If the rotation is variable, select the lower rotation. Plane for woodwork can be used for chamfering. Guide ruler will help you to ensure a uniform edge.

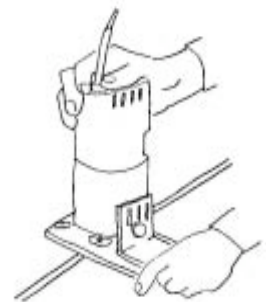

**(4) Punching and notching**

Punching die can be used for cutting out and making holes. The suitable clearance between punch and die is 0.1mm or smaller (material thickness approx. 2%). Small droop will appear at punched edge.

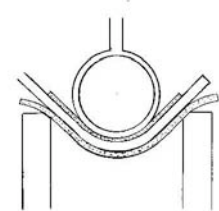
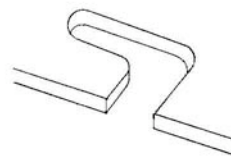

**(5) Bending with press brake**

ALPOLIC/fr LT is bendable under room temperature with press brake. The minimum bendable radius with press brake is shown in above "5. Characteristics."

**(6) Bending with 3-roll bender**

Manual or electric-drive 3-roll bender can be used for bending ALPOLIC/fr LT. The minimum bendable limit is 130-230 mm in radius depending on the length of the bender. The suitable clearance between rolls is the panel thickness (3mm) plus approx. 0.5mm.

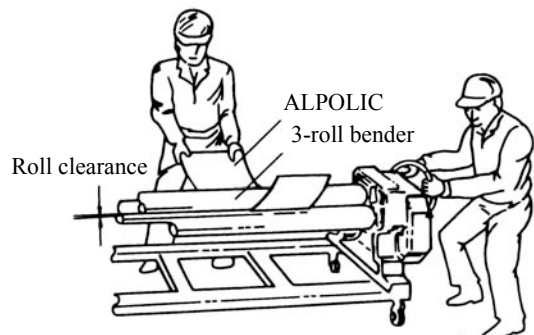

### **(7) CNC router**

ALPOLIC/fr LT panels can be cut, notched and grooved with CNC router, equipped with suitable bits. As a series of processing is automated with a computer program, CNC router is suitable for repetition of the same procedures. The same bit and operating conditions as hand router can be applied to CNC router.

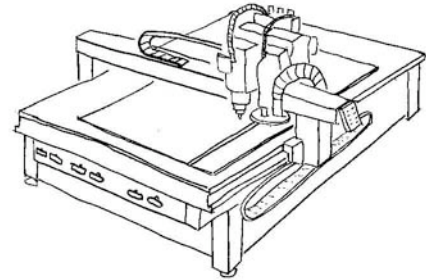

### **(8) Joining**

#### **A. Rivet and bolt/nut:**

Rivets, bolt/nut and tapping screws are often used for junction between ALPOLIC and aluminum extrusions. Use aluminum blind rivet. We can do riveting work from one direction. Use stainless steel bolt/nut, and tapping screw made of aluminum or stainless steel.

#### **B. Welding of core**

By means of hot melt adhesives, one exposed core can be connected to another exposed core of ALPOLIC/fr LT. Normally, reinforcement is necessary after welding.

#### **C. Adhesives**

When ALPOLIC/fr LT is adhered to different material with adhesives, it is possible that ALPOLIC/fr LT shows a slight distortion with the thermal expansion difference or dimension change of the substrate material. It depends on the joining conditions, so pre-check the possibility of the distortion before use.

2-component epoxy type, polyurethane type and silicone type adhesives often show a shrinkage during hardening and result in a slight deformation of the adhered portion, which can be visible from surface side of the panel. Do not use these adhesives except for concealed area.

#### **D. Double-sided tape**

Double-sided tape like 3M's VHB tape is effective in joining ALPOLIC/fr LT to other materials. VHB tape simplifies the joining work. Thick ones allow a movement of the adhered two materials to some extent.

### **(9) Sealant**

In order to ensure waterproofing of joints between panels, normally a sealing material is used. The sealing material shall meet the performance required for the atmosphere. Silicone, modified silicone, polysulfide and polyurethane sealant are used. Among these materials, silicone sealant is the best in weatherability, but, as widely known, it is possible to stain panel surface. Regarding the joint design such as joint width and thickness, please follow the sealant manufacturer's specifications.

### **(10) Screen printing**

In screen-printing, use epoxy type or polyurethane type ink of one component or 2-component type. The typical printing procedures are as follows:

- (1) Remove all dust and dirt with soft cloth. Oily dirt, if remaining, causes printing defects.
- (2) Cure or dry under proper conditions. Follow instructions from ink manufacturer.

## 9. Examples of installation method

### (1) Internal wall cladding with hanging system

#### Horizontal section

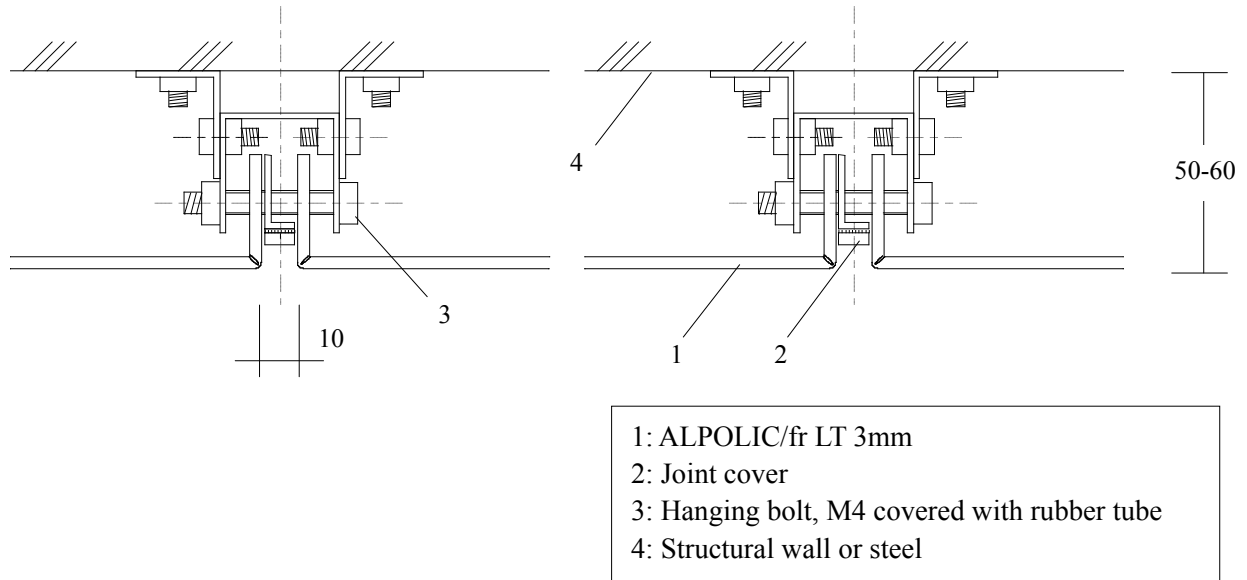

### (2) Ceiling installed on lightweight suspension bar system

#### Section of the longer panel side

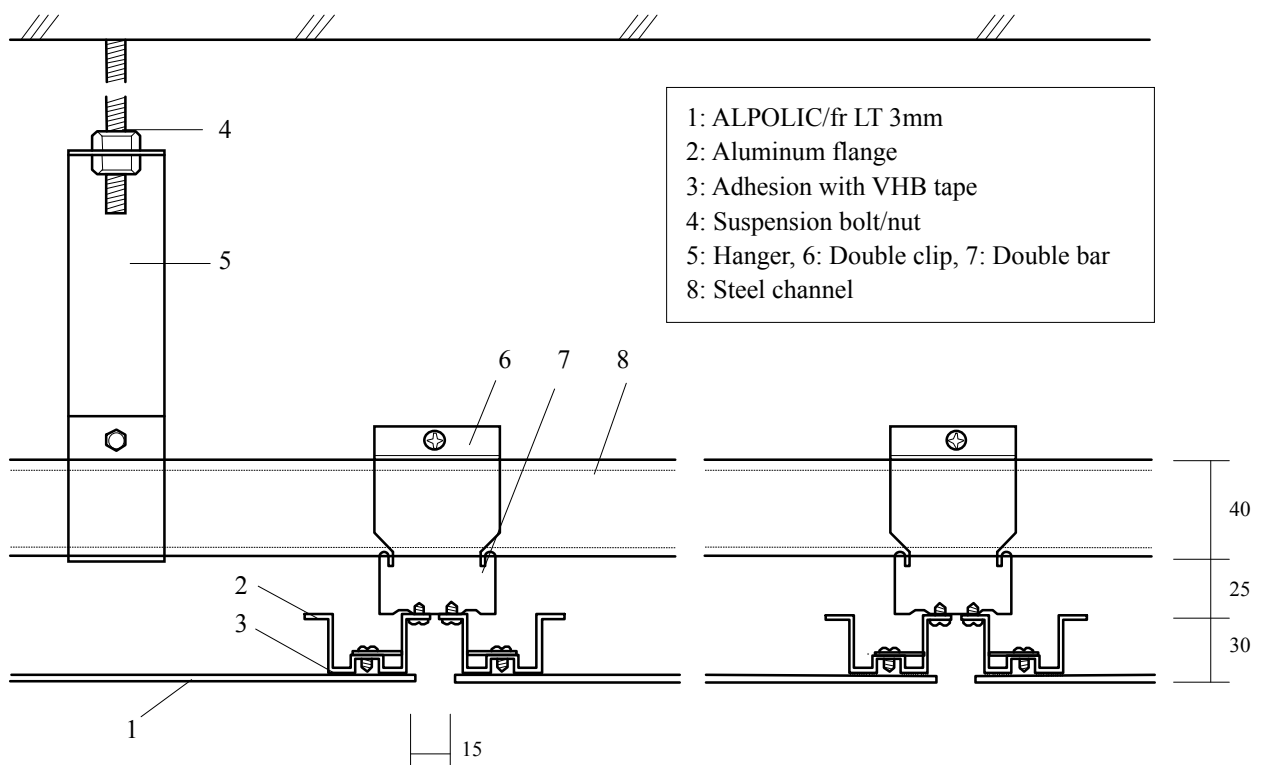

### Section of the shorter panel side

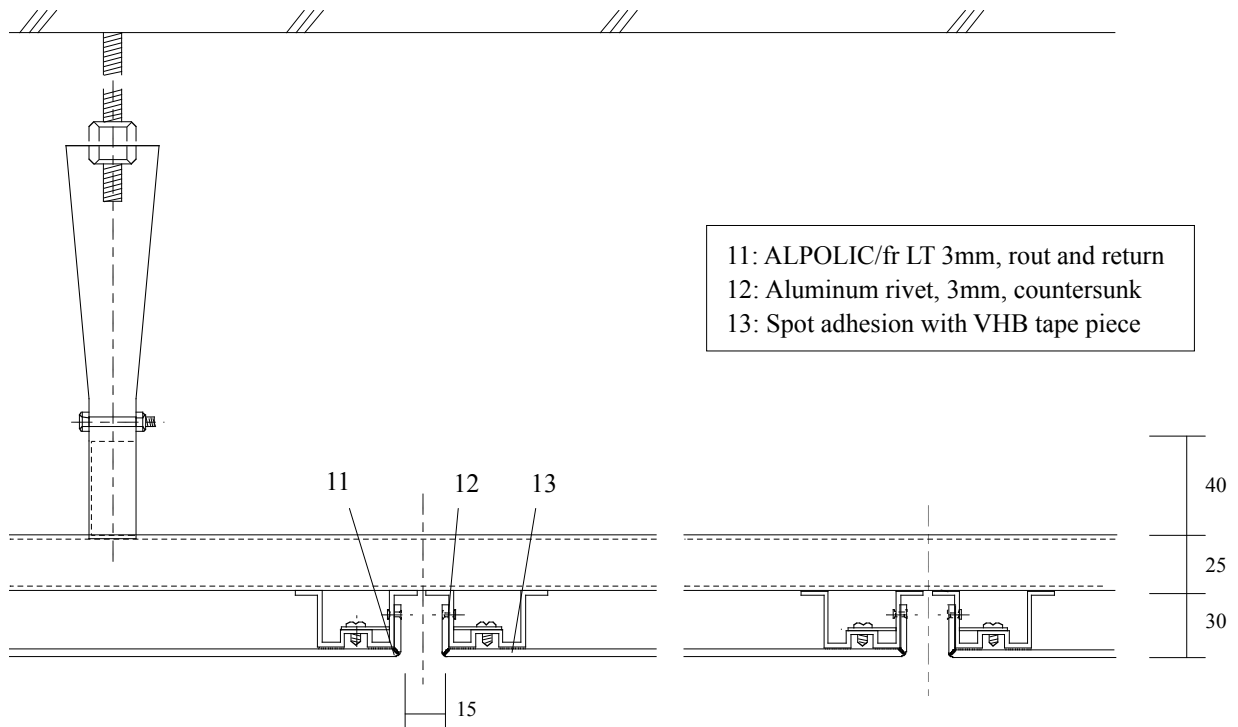

### 10. General notes

#### (1) Thermal expansion/contraction

Linear thermal expansion coefficient of ALPOLIC/fr LT is the same as aluminum metal. Therefore, movement will not occur between aluminum and ALPOLIC/fr LT. However, a certain extent of movement is anticipated between ALPOLIC/fr LT and structural materials such as steel and concrete. This movement is normally very small (0.5mm/m or 0.02"/3') in case of indoor applications, but it must be relieved with a suitable method such as spacing between panels. In outdoor applications, the temperature change will be nearly twice of the above.

#### (2) Prevention from edge corrosion

ALPOLIC/fr LT has a corrosion resistant primer behind aluminum skins to prevent the edge from corrosion, and ALPOLIC/fr LT is a non-permeable material. But we still recommend a careful panel detail in which cut edge is not exposed to corrosive or outdoor atmosphere for long time. When ALPOLIC/fr LT is used in a humid area such as in bathroom, it is important to drain the moisture to keep the edge dry.

#### (3) Coating direction

In Metallic Colors, slight color difference will be noticeable between the panels installed in different directions (like Panel A and B). Install panels in the same direction as marked behind the panel. The same note holds true in Stone and Timber panels. In Solid Colors, the color difference due to coating direction is negligible.

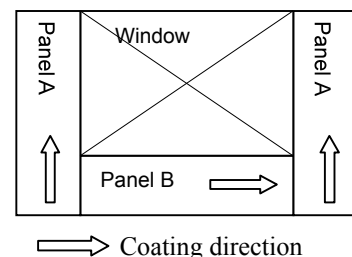

#### (4) Note on protective film

The effective surface(s) are protected with translucent protective film. Do not remove it during fabrication and installation. Remove it immediately after installation work in order to avoid the problems due to degradation of the protective film. Especially in Reversible Type, in which the protective films are applied on the both sides, make sure that films are peeled off from both sides. Note that the protective film does not resist UV for long time, unlike the protective film applied to the ALPOLIC®/fr for outdoor applications.

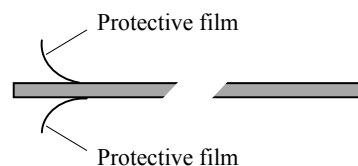

#### (5) Note on cleaning

Do not use strong organic solvents, such as MEK (Methyl Ethyl Ketone), MIBK (Methyl Iso Butyl Ketone), Triclene and paint thinner. Do not use strong alkali, strong acid or abrasive cleaners. If these solvents and cleaners are used, the paint might be swollen or removed. Make sure that cleaning sponges or rags are grit-free, to prevent the coated surface from scratch. Avoid over cleaning or excessive rubbing.



#### Recycling

ALPOLIC/fr LT is being recycled. Scraps generated from ALPOLIC plants and nominated fabricators' workshop are collected to the recycling facility provided in ALPOLIC plant for recycling.

#### ISO 9001:2000 Certified

ALPOLIC/fr LT, through the design, development, manufacture and sales, is managed with ISO 9001:2000.

#### ISO 14000:

ALPOLIC/fr LT is produced in the plant that has ISO14000 certificate.

For further information, please contact:

mitsubishi chemical functional products, inc.  
Composite Materials Division  
Tekko Building, 8-2, Marunouchi 1-chome, Chiyoda-ku Tokyo 100-0005  
Japan  
Telephone: 81-3-3287-8124  
Facsimile: 81-3-3287-8133  
E-mail: 1605495@cc.m-kagaku.co.jp

mitsubishi chemical singapore pte ltd  
Composite Materials Department  
79 Anson Road, #12-01 Singapore 079906  
Telephone: 65-6226-1597  
Facsimile: 65-6221-3373  
E-mail: SIN0027@cc.m-kagaku.co.jp

mitsubishi chemical america, inc.  
Composite Materials Division  
401 Volvo Parkway, Chesapeake, VA 23320  
Telephone (USA): 800-422-7270  
Telephone (International): 757-382-5750  
Facsimile: 757-436-1896  
E-mail: info@alpolic.com