

## **FABRICATION MANUAL ANODIZED**

You discover why Anodized ALPOLIC® aluminum composite material (ACM) is the building material of the future as soon as you fabricate it. The Anodized ALPOLIC has a class one clear or dyed anodic layer. It is as easy to fabricate as wood no special tools are required. It can be curved, bent, routed, drilled, sawed, sheared, punched, trimmed and molded into complex shapes with conventional woodworking or metalworking tools. Anodized ALPOLIC®'s versatility makes it readily adaptable to many other standard systems that are available from a variety of vendors, including rout & return systems, glazed-in systems and creative custom systems. In addition, you can create complex assemblies with Anodized ALPOLIC® in combination with polyethylene welding and support systems attached with structural adhesives. Anodized ALPOLIC® surfaces can be connected to one another or to other materials by such conventional methods of attachments as rivets, bolts or screws.

For further design, detailing and fabrication guidance, please refer to the materials in this section, or go to [www.alpolic-usa.com](http://www.alpolic-usa.com). For samples or a list of authorized ALPOLIC® fabricators, please call the ALPOLIC® Hotline toll-free at 1-800-422-7270, or e-mail us at [info@alpolic.com](mailto:info@alpolic.com).

## Visual Consistency

The American Architectural Manufacturer's Association (AAMA) has issued the "Voluntary Specification for Anodized Architectural Aluminum" AAMA611-98. In this specification the maximum allowable color variation is established as Delta E CMC 5.0 or less for anodized materials produced from one coil. Delta E CMC is a corrected color space and has been selected by AAMA to better correlate with the visual appearance. The specification does not provide a limit for variation seen between materials for different coils. In anodized finishes, especially clear anodized, the make up of the metal can greatly affect the visual appearance. Small variations in the alloy's constituents can have a large visual impact. For this reason care must be taken to use only one lot of anodized product on a building face. The anodized finish also has directionality so the alignment of the directional arrows is important.

# PROPERTIES

## Thermal Expansion/Contraction

Thermal expansion/contraction must be considered when designing with ALPOLIC®./ APOLIC fr

To calculate thermal expansion/contraction, use the following equations:

$$\text{Thermal Expansion/Contraction (inches)} = 12 \times \text{Cth} \times \Delta T(^{\circ}\text{F}) \times \text{L(feet)}$$

Cth = Coefficient of thermal expansion (13 x 10-6)

L = Length of ALPOLIC panel

$\Delta T = T_a - T_i$  where  $T_a$  is the actual temperature and  $T_i$  is the temperature when ALPOLIC was fabricated or installed. A positive  $\Delta T$  indicates expansion and negative  $\Delta T$  indicates contraction.

## Thermal Expansion/Contraction Per Foot (inches)

$\Delta T$	10	20	30	40	50	60
4,6mm	0.0016	0.0031	0.0047	0.0062	0.0078	0.0094
$\Delta T$	70	80	90	100	110	120
4,6mm	0.0109	0.0125	0.0140	0.0156	0.0172	0.0187

## Fire Resistance Properties

	ALPOLIC		ALPOLIC/fr	
	4mm/.157"	6mm/.236"	4mm/.157"	6mm/.236"
Surface burning ASTM E84				
Smoke developed index	0	10	10	0
Flame spread index	0	0	0	0
ASTM E108 (modified)				
Vertical transmission	Passed	Passed	Passed	
Ignition temp. ASTM D1929				
Flash ignition:	716°	716°	811°F	811°F
Self ignition:	752°	752°	837°F	837°F
Rate of burning ASTM D635	CC1	-	-	
ISMA test UBC 26-9	-	-	Passed	Passed
Potential heat release UBC 17-2	-	-	<6,000BTU/ft2	
Combustion gas toxicity (U of Pitt)	-	-	No more toxic than wood	No more toxic than wood

## Physical Properties: ALPOLIC

Item	Unit	ASTM	ALPOLIC	
			4mm	6mm
Specific gravity			1.38	1.23
Weight lb/ft			1.12	1.50
Thermal expansion	10- <sup>6</sup> /°F(-4-140°F)	D-696	13	13
Thermal conductivity	BTU/ft hr °F(apparent)	C-976	0.14	0.17
Thermal resistance	Ft·hr°F/BTU(apparent)	C-976	0.09	0.12
Deflection temperature	°F	D-648	232	231

## Mechanical Properties: ALPOLIC

Item	Unit	ASTM	ALPOLIC	
			4mm	6mm
Tensile strength	PSI	E-8	6,900	4,900
Yield strength	PSI	E-8	6,400	4,400
Elongation	%	E-8	14	17
Modulus of bending elasticity (8" span)	10 <sup>6</sup> lb/in <sup>2</sup>	E-8	6.2	4.7
Punching Shear Resistance				
Maximum load	Lb	D-732	1,920	2,120
Shear resistance (1"Ø)	PSI	D-732	4,000	2,800

## Dent (Impact) Test by DuPont Method: ALPOLIC

Dent Depth (x10 <sup>-3</sup> in) ALPOLIC			
Steel ball (lb)	Height (in)	4mm	6mm
0.66	2	0.59	0.47
0.66	12	2.01	1.38
1.10	20	5.28	3.50
2.20	12	6.18	4.25
2.20	20	8.43	6.42

## Engineering Properties: ALPOLIC fr

Property	Unit	ASTM	ALPOLIC/fr Total thickness	
			4mm/.157"	6mm/.236"
Aluminum Thickness	in		0.020	0.020
Specific Gravity			1.90	1.81
Weight	lbs/ft <sup>2</sup>		1.56	2.23
Coefficient of Expansion	in/in/°F	D-696	13x10 <sup>-6</sup>	13x10 <sup>-6</sup>
Tensile Yield Strength	psi	E-8	6344	3840
Tensile Strength	psi	E-8	7126	4266
Elongation	%	E-8	5.0	2.0
Flexural Elasticity	psi	C-393	5770x10 <sup>3</sup>	4220x10 <sup>3</sup>
Flexural Stiffness	psi	C-393	1.93x10 <sup>9</sup>	4.98x10 <sup>9</sup>
Punching Shear Resistance				
> Max. Load	lbs	D-732	2259	
> Shear Resistance	psi	D-732	4637	
Deflection Temperature	°F	D-648	241.8	228.8

## Impact Resistance: ALPOLIC fr

		ALPOLIC/fr Dent depth (x10 <sup>3</sup> in)	
Steel Ball	Height	4mm/.157"	6mm/.236"
1.10 lb	20 in	5.07	3.93
2.20 lb	12 in	5.47	4.72
2.20 lb	20 in	7.40	6.30

**Production Tolerance: ALPOLIC/ALPOLIC fr**

Width	±0.08" (2mm)
Length	±0.16" (4mm)
Thickness	±0.008" (.2mm) ±0.012" (.3mm)
Bow	Maximum 0.5% of the length and/or width
Squareness	Maximum 0.2"

**Body Integrity**

			ALPOLIC	ALPOLIC	ALPOLIC/fr
Item	Unit	ASTM	4mm/.157"	6mm	4mm/.157"
Vertical pull	PSI	C-297	1,800	1,650	427
Drum peel	In-lb/in	D-1781-76	33.6	33.6	27.6
Nmm/mm	D-1781-76	150	150	123	110
Flatwise shear	PSI	C-273	1,220	1,195	949

## Vibration Damping

As a laminated composite material, ALPOLIC® can dampen vibration by either absorbing vibration energy or converting it into thermal energy.

Vibration Damping (at 73.4°F)

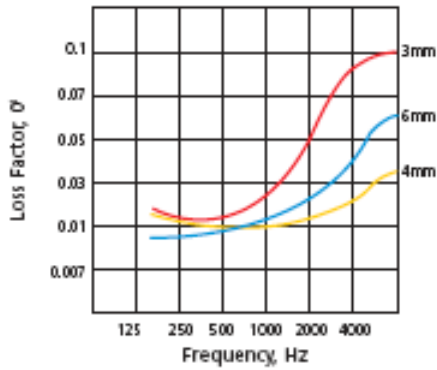

## Sound Transmission

When tested in conformity with ASTM E-413, the following sound transmission classes (STC Nos.) were established:

- 4mm-STC 26
- 6mm-STC 26

Sound Transmission 4mm

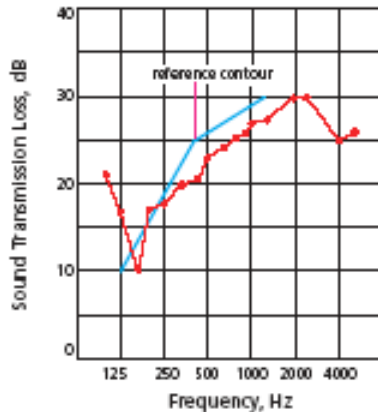

Sound Transmission 6mm

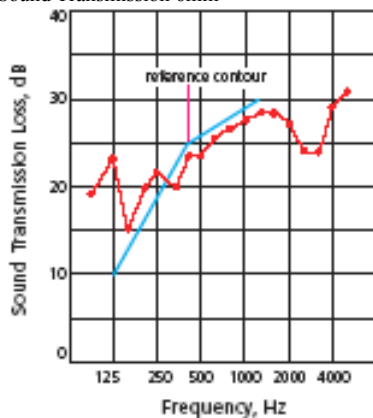

## Wind Load Deflection

Wind load deflection depends on the thickness, aspect ratio, span and boundary condition (whether ALPOLIC® is simply supported or fixed).

The aspect ratio is the ratio of the longer to the shorter dimension of a panel. Panels with the same area but different aspect ratios will have different wind load deflections. For example, a 2' x 8' panel with an aspect ratio of 4 will have a smaller wind load deflection than that of a 4' x 4' panel with an aspect ratio of 1.

Wind Load Deflection: 4mm

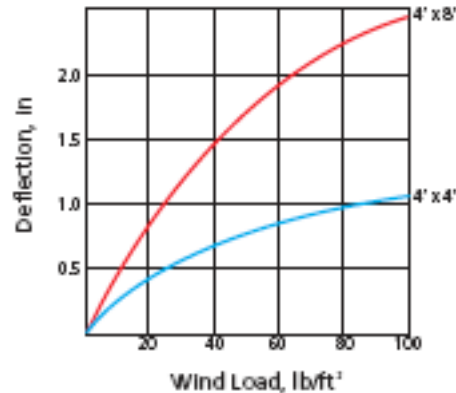

Wind Load Deflection: 6mm

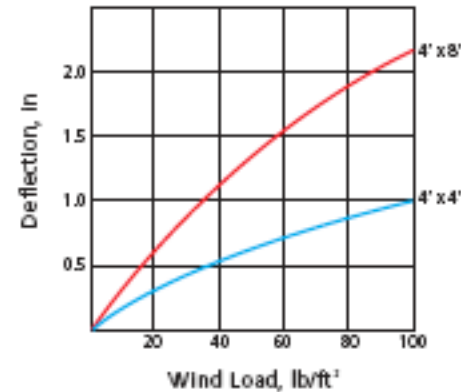

**For more information and calculations for wind load and deflection please refer to the download section of ALPOLIC-USA.com**

# MECHANICAL PROCESSING

## ***Cutting/Saw***

ALPOLIC<sup>®</sup> can be easily cut using standard woodworking saws (i.e. circular hand saw or panel saw). A carbide tip blade made for aluminum and plastic is the most suitable for cutting ALPOLIC<sup>®</sup> (Refer to next page).

## ***Cutting/Shear***

Square shear cutting is the easiest method for cutting large panels. Some shear droop may result at the cut part of the aluminum surface material.

For shear cutting ALPOLIC<sup>®</sup>: recommended rake angle for shear cutting as listed below.

<i>Thickness of ALPOLIC<sup>®</sup></i>	<i>Clearance</i>	<i>Rake angle</i>
3 mm	0.002"	1°
4 mm	0.002"	1° 30'
6 mm	0.008"	2° 30'

## ***Edge Finishing***

When a smooth finished edge is required on ALPOLIC<sup>®</sup>, the following equipment can be used to provide the specific requirements: woodworking planer or shaper, tenoning machine or milling machine.

The edging process provides smooth, crisp, clean edges, to insure clean joint intersections or to create a detailed frame effect when angled.

## ***Processing***

Because of ALPOLIC<sup>®</sup>'s composite makeup, the following process is required to fabricate sharp angle bends. This requires routing or cutting either a 'V' or 'U' groove in the ALPOLIC<sup>®</sup>, as shown, to provide the required bend.

Observe the following recommendations in 'U' or 'V' cut processing:

The 'U' or 'V' cut bottom should not reach to the back of the aluminum. Leave about 0.008 - 0.016" of polyethylene core.

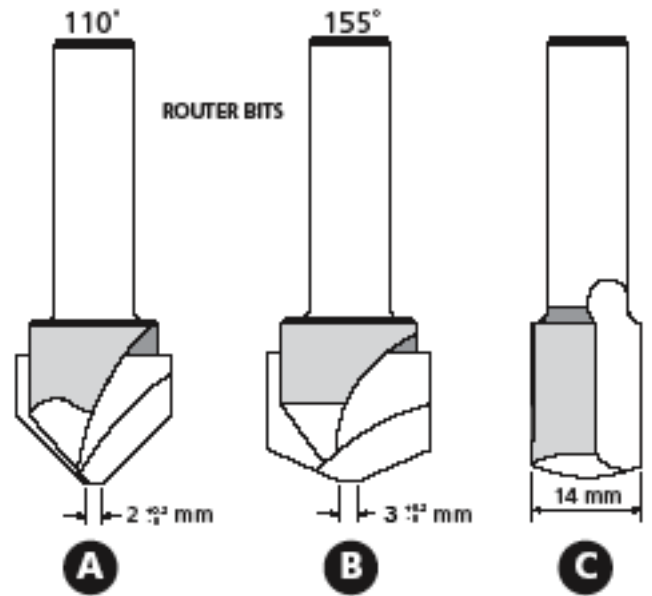
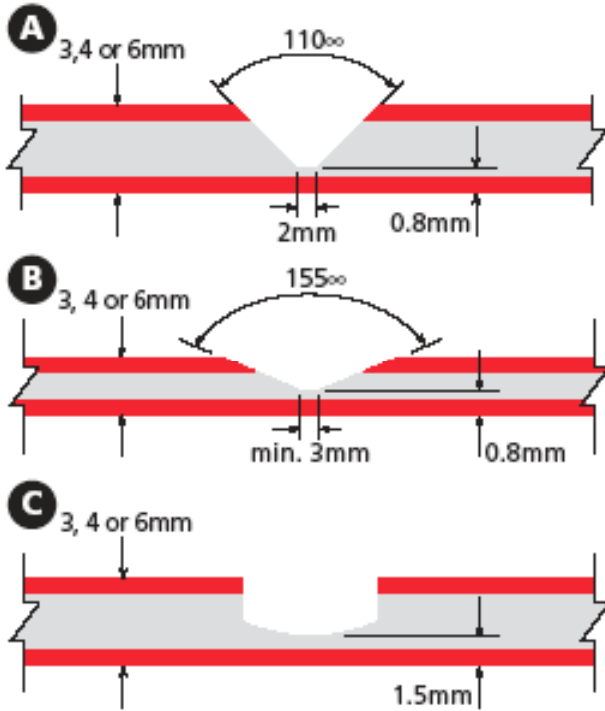

### Router and Trimmer Tools

Use the bit as shown in the drawings below, which corresponds to the cut diagrams above.

Number of teeth	2 - 4
Rotation speed	20,000 - 30,000 rpm
Feeding speed	10 - 16 ft/min.
Material	Carbide

## Saw/Milling Cutters

<i>Carbide Tip Saw Example</i>	
Outside diameter	12" 0
Number of teeth	36 (saw) 8 (grooving)
Rotation speed	3,000 - 5,000 rpm (variable motor)
Feeding speed	16 ft/min.

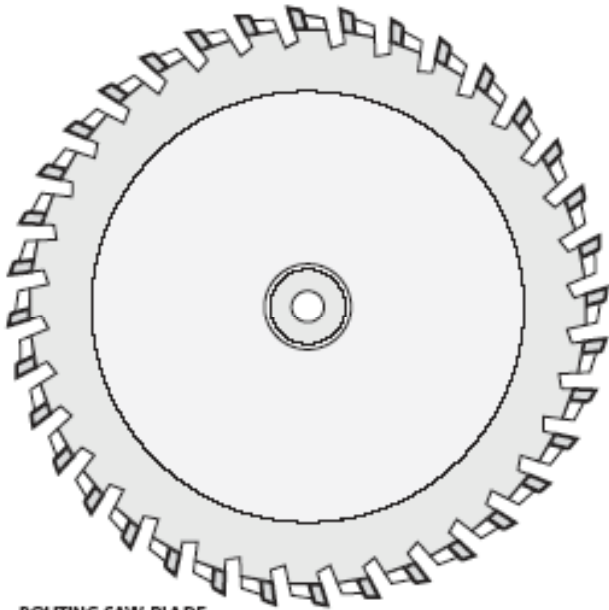

ROUTING SAW BLADE

Observe the following recommendations in 'V' or 'U' cut processing:

The 'V' or 'U' cut bottom should not reach to the back of the aluminum. Leave about 0.008 - 0.016" of polyethylene core.

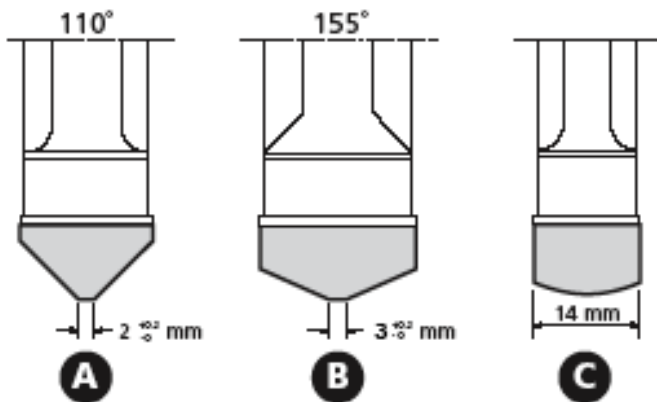

## Bending

The anodic film on the surface of the ALPOLIC panels is brittle and there will be some surface cracking at the bent edge when doing a rout and return

ALPOLIC® should be processed on a flat surface, void of irregularities, to insure consistency in the depth of the 'V' or 'U' grooving. This will insure a smooth clean edge when bent.

If available, a plate or break press should be used to bend processed ALPOLIC®. When this is not possible a simple bending jig made of wood or metal is recommended.

When ALPOLIC® is processed with a 'V' groove and bent at 90°, the finished panel dimension will increase by approximately 1/8". This should be factored into the panel dimensions before final fabrication. It is advisable to do a preliminary test to insure the proper adjustment necessary.

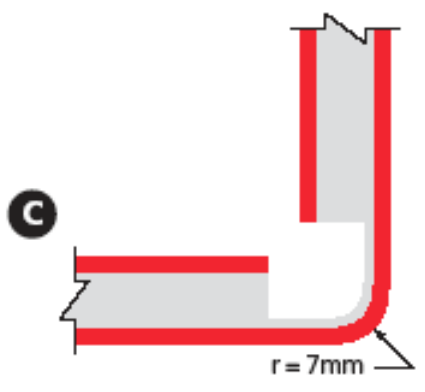
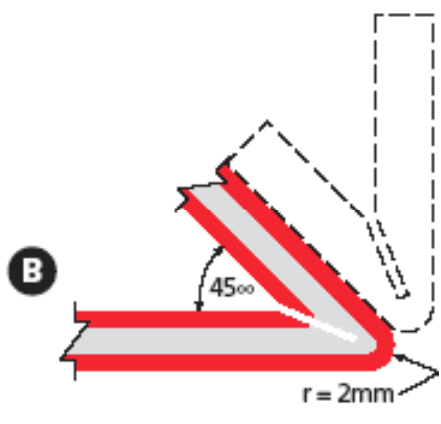
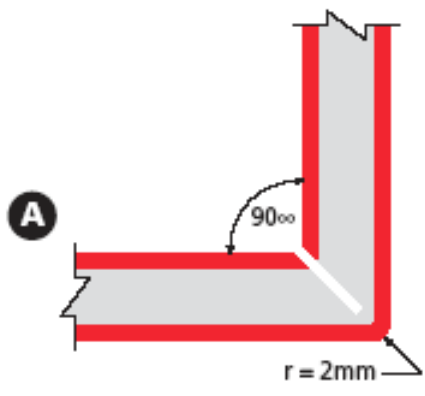

## Curving

Due to the brittle nature of an anodic layer curving and bending of anodized ALPOLIC is not recommended. The anodic layer will fracture creating a visually objectionable surface.

## Punching/Drilling

### Punching

Punching with a press sometimes causes shear droop in the aluminum surface material similar to shear cutting. It is preferable that the clearance of punch and die be made as small as possible (thickness of panel times 5%).

In the case of a small diameter hole (under 1/6") the tool may need to be modified as shown below to ensure that the polyethylene is completely removed in the process.

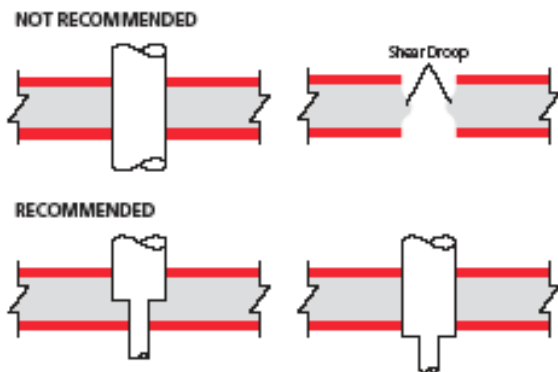

### Drilling

ALPOLIC<sup>®</sup> can be drilled with standard twist drills used for aluminum and plastics.

#### WORKING SPECIFICATIONS:

- Drill bit: Twist drill, high speed steel.
- Tip Angle: 100-140 degrees, or counter-bore grind with centering tip.
- Cutting speed: 164 RPM to 984 RPM.

Quick removal of chips can be achieved by a high RPM, slow feed speed and occasional lifting of the bit.

# ATTACHMENT CONCEPTS

Please reference the joint details diagrams in the download section on ALPOLIC-USA.com

## JOINING ADHESION

Typical methods of joining ALPOLIC® are the use of threaded fasteners, rivets, adhesives and double-faced high strength tapes. Proper consideration should be given to the thermal expansion characteristics of ALPOLIC®.

Use the general guidelines listed below when other elements come in direct contact with the surface of ALPOLIC®. When attaching copper, iron, brass, raw steel and bronze consideration needs to be given to the possible corrosion of joining surface due to electrolysis of dissimilar materials. If these materials must be used, make sure that a protective coating or separation exists between the two surfaces.

### Threaded Fasteners

When using threaded fasteners, caution should be taken not to over tighten the fastener. The examples below show different threaded fastening methods.

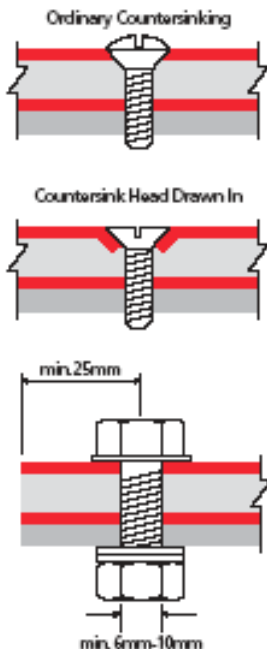

### Rivets

Rivets can be used to fasten ALPOLIC® panels together or to aluminum extrusion profiles. Rivets are especially suitable for fastening when vibration is likely. Colored plastic concealment caps can be used to conceal exposed rivet heads.

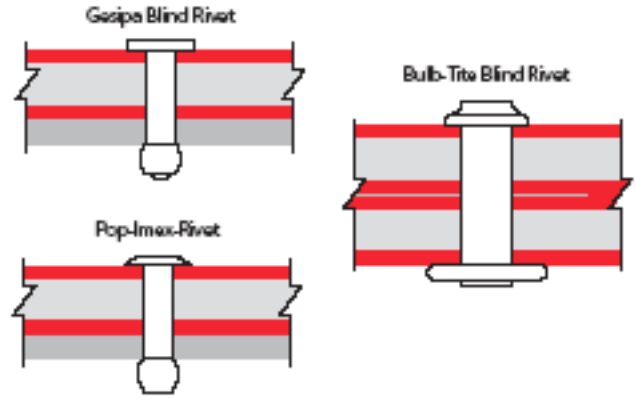

### Adhesives & High Bond Tapes

When the ALPOLIC® attachment surface is flat (i.e. wall, ceiling, sign board, etc.) construction adhesive or double-faced high bond tapes can be used for installation. See the technical bulletin on ALPOLIC and VHB tapes in the download section of ALPOLIC-USA.com. See recommended adhesive supplier for more details.

### Adhesives for ALPOLIC®

Adhesives suitable for adhering ALPOLIC® to various kinds of substrates are shown in the following table.

Kind of Adhesives	Substrate				
	A	B	C	D	E
Epoxy-based	•	•	•	•	•
Acrylate-based	•	•	•		•
Chloroprene-based	•		•		•
Nitrile rubber-based	•		•		•
a-cyano acrylate-based					

## Welding/Hot Melt

### Hot Air Welding

This process is used to join ALPOLIC® panels through a process of welding the polyethylene core.

### Edge Preparation

ALPOLIC® parts should have edges beveled to the corresponding angle of the finished part and allowing an exposed surface on the welded side. A low-density polyethylene rod should be used in conjunction with a high-speed hot air welder equipped with a pressing apparatus.

WELDING SPECIFICATIONS	
Welding Temperature:	446 - 464° F
Air Pressure:	0.10-0.14 lb/in
Pressing Pressure:	2.2-3.3lbs.
Welding speed:	40 in/min.

### Conditions for Hot Air Welding

Welding Temperature	446 - 464° F
Pressure of air compressor	0.10 - 0.14 lb/in <sup>2</sup>
Pressing pressure	2.2 - 3.3lb
Welding speed	40 in/min.

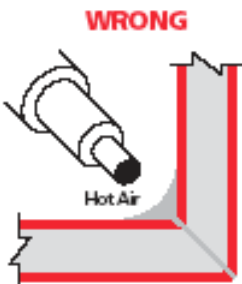
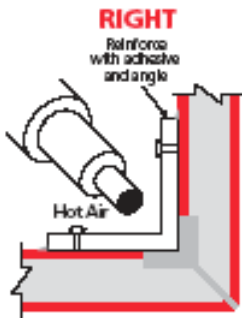

### Hot Melt

When using Hot Melt systems to bond ALPOLIC®, be sure that the surfaces to be bonded have been abraded and cleaned.

Hot Melt adhesives designed for bonding aluminum or metals are recommended. To insure the maximum bonding, please consult the adhesive manufacturer.

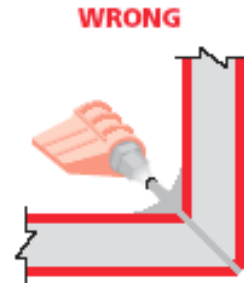

## APPENDICES

### ***Off-line Coating***

ALPOLIC<sup>®</sup> can be off-line coated, if necessary. It is advisable to follow instructions as specified by the manufacturer of any paints to be used.

*For off-line coating observe the following guidelines:*

- Surface should be lightly abraded to provide a better coating surface. Surface should then be cleaned of all contaminants i.e. dust, dirt and oil etc. A soft cloth with a non-petroleum based solvent (e.g. rubbing alcohol) should be used to clean the surface area.
- Curing should be done at room temperature since temperatures above 175°F can cause deformation of the ALPOLIC<sup>®</sup> panel.

### ***Screen Printing***

Printing can be done on ALPOLIC<sup>®</sup> with an epoxy base or urethane base two-part type ink/paint.

In printing, use polyester-coated or anodize-finished ALPOLIC<sup>®</sup>.

When selecting an ink, confirm its weatherability and adhesion with the ink manufacturer. It is recommended to test the ink's adhesion on the surface of the ALPOLIC<sup>®</sup> before production.

*For printing on ALPOLIC<sup>®</sup>, observe the following guidelines:*

- Remove all dust and dirt on the surface of ALPOLIC<sup>®</sup>. Oily dirt causes splintering, splitting, or other defects of the paint. It must be completely removed with a soft cloth dipped in alcohol, N-hexane, etc.
- If storing or drying is not proper, the adhesion or other performance may be adversely affected. Therefore, observe the storing condition of each paint as specified by the manufacturer.
- Since storing in high temperature may cause deformation, keeping the storing temperature under 175°F and hold

## **Masking**

ALPOLIC<sup>®</sup> comes with a factory applied protective masking film which should be removed after fabrication.

## **Storage**

ALPOLIC<sup>®</sup> is packed in wooden crates and can usually be stacked up to four crates high.

*When storing unpacked ALPOLIC<sup>®</sup> observe the following guidelines:*

- To prevent warping or bending, place it horizontally on pallet or other stand.
- Avoid stacking ALPOLIC<sup>®</sup> of different sizes together, as the surface or panel can be scratched by the edges of the smaller pieces.
- Preferably, store them by size in racks.
- In storing them by leaning against the rack as shown below, lay a rubber mat underneath and lean the ALPOLIC<sup>®</sup> closely against the fixed back-up material.

**RACKING SYSTEM**

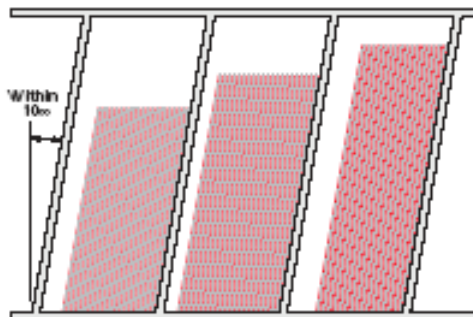

## **Cleaning**

To clean the anodized ALPOLIC surface follow the recommendations as detailed in the Voluntary Guide Specification for Cleaning and Maintenance of Architectural Anodized Aluminum AAMA 609